

The following erratum presents the corrections and revision of ANSI/HI 9.8-2018 Standard for Rotodynamic Pumps for Pump Intake Design. An erratum is issued to change and revise any editorial corrections or errors introduced during the publishing process of an existing published Hydraulic Institute standard/guideline.

Please note that this document is released with the acknowledgement and consideration of all other previous revisions made since the last publication of the standard.

The Hydraulic Institute and its affiliates caution and encourage all users to ensure that they have the latest edition of any HI standard by periodically checking the following URL:
<http://www.pumps.org/standardsupdates.aspx>

A single strike through of text indicates deletion, while a single underline indicates an addition. For formulas, figures and graphics, a dashed, gray line will be placed over the original reproduced object. The new or updated object will be presented in the same manner as it should appear in the standard.

Page	Change
19	Figures 9.8.3.3.1d, e, & f

Original Figures

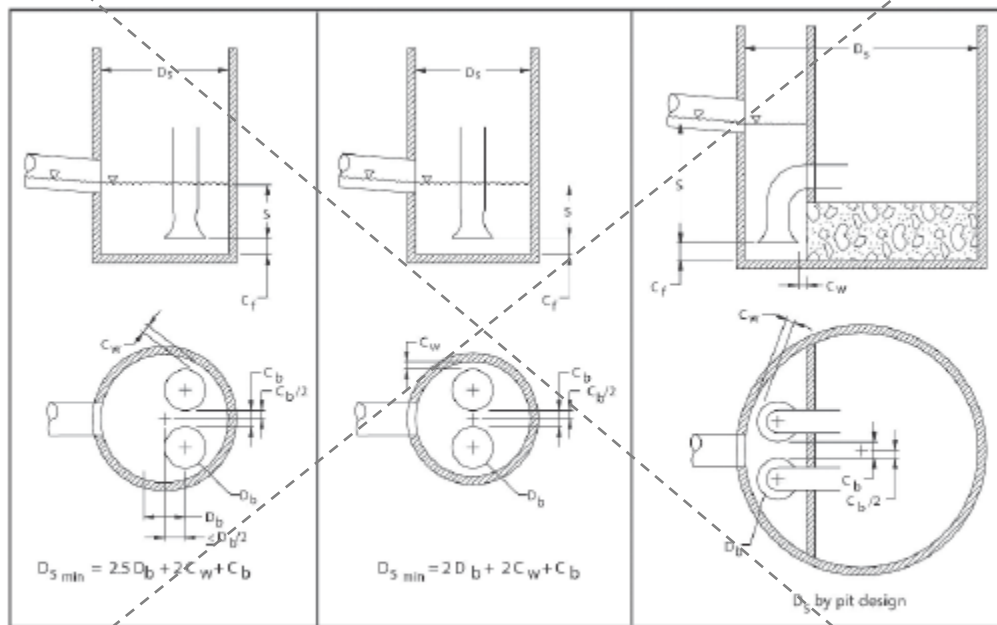

Figure 9.8.3.3.1d
Wet-pit triplex sump,
pumps in line

Figure 9.8.3.3.1e
Wet-pit triplex sump,
compact

Figure 9.8.3.3.1f
Dry-pit/wet-pit triplex
sump

Corrected Figures

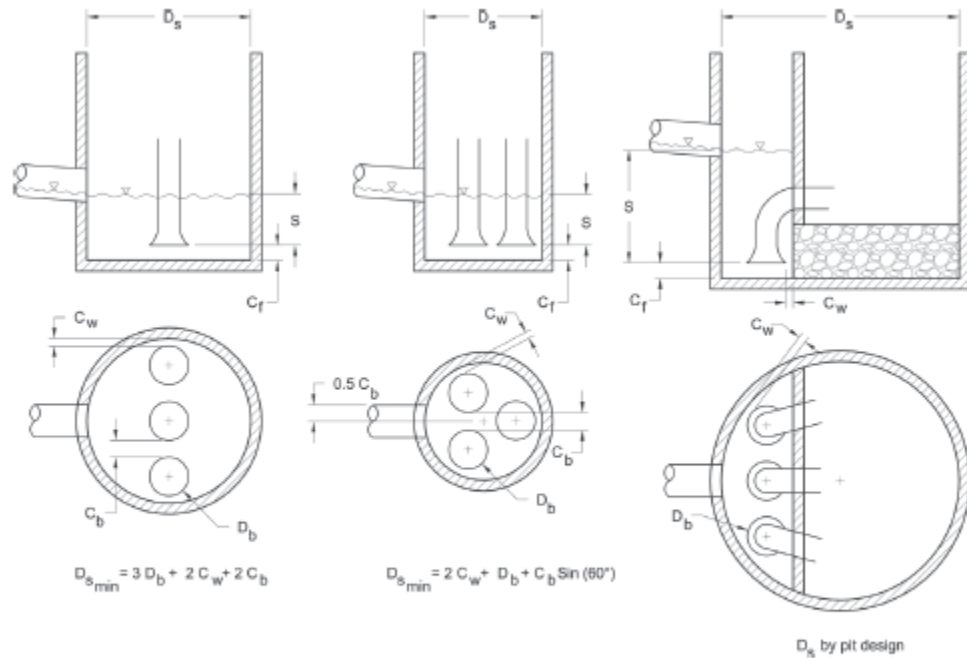

Figure 9.8.3.3.1d
Wet-pit triplex sump,
pumps in line

Figure 9.8.3.3.1e
Wet-pit triplex sump,
compact

Figure 9.8.3.3.1f
Dry-pit/wet-pit triplex
sump